

---

# HD-SDI Video Capture Device

Model 2267

## Hardware Manual

Ver. 1.0.2 | July 2024

SENSORAY | embedded electronics |



Designed and manufactured in the U.S.A

SENSORAY | p. 503.684.8005 | email:info@SENSORAY.com | [www.SENSORAY.com](http://www.SENSORAY.com)

7313 SW Tech Center Drive | Portland, OR 97203

---

# Table of Contents

Limited warranty .....	3
Introduction .....	4
System requirements .....	5
Block diagram.....	6
Connectors .....	7
USB, J1.....	7
Audio inputs, JP1 .....	7
RS232, GPIO, JP2.....	7
Specifications .....	9
Software.....	10
Firmware updates .....	11
Revision history.....	12

## Limited warranty

Sensoray Company, Incorporated (Sensoray) warrants the hardware to be free from defects in material and workmanship and perform to applicable published Sensoray specifications for two years from the date of shipment to purchaser. Sensoray will, at its option, repair or replace equipment that proves to be defective during the warranty period. This warranty includes parts and labor.

The warranty provided herein does not cover equipment subjected to abuse, misuse, accident, alteration, neglect, or unauthorized repair or installation. Sensoray shall have the right of final determination as to the existence and cause of defect.

As for items repaired or replaced under warranty, the warranty shall continue in effect for the remainder of the original warranty period, or for ninety days following date of shipment by Sensoray of the repaired or replaced part, whichever period is longer.

A Return Material Authorization (RMA) number must be obtained from the factory and clearly marked on the outside of the package before any equipment will be accepted for warranty work. Sensoray will pay the shipping costs of returning to the owner parts that are covered by warranty. A restocking charge of 25% of the product purchase price will be charged for returning a product to stock.

Sensoray believes that the information in this manual is accurate. The document has been carefully reviewed for technical accuracy. In the event that technical or typographical errors exist, Sensoray reserves the right to make changes to subsequent editions of this document without prior notice to holders of this edition. The reader should consult Sensoray if errors are suspected. In no event shall Sensoray be liable for any damages arising out of or related to this document or the information contained in it.

**EXCEPT AS SPECIFIED HEREIN, SENSORAY MAKES NO WARRANTIES, EXPRESS OR IMPLIED, AND SPECIFICALLY DISCLAIMS ANY WARRANTY OF MERCHANTABILITY OR FITNESS FOR A PARTICULAR PURPOSE. CUSTOMER'S RIGHT TO RECOVER DAMAGES CAUSED BY FAULT OR NEGLIGENCE ON THE PART OF SENSORAY SHALL BE LIMITED TO THE AMOUNT THEREFORE PAID BY THE CUSTOMER. SENSORAY WILL NOT BE LIABLE FOR DAMAGES RESULTING FROM LOSS OF DATA, PROFITS, USE OF PRODUCTS, OR INCIDENTAL OR CONSEQUENTIAL DAMAGES, EVEN IF ADVISED OF THE POSSIBILITY THEREOF.**

Third party brands, names and trademarks are the property of their respective owners.

# Introduction

Model 2267 captures video from SDI or HD-SDI video sources. It has a USB 2.0 interface. It will overlay and compress resolutions up to 1080p30. It can simultaneously send both compressed and scaled down uncompressed video to the host computer.

Audio can be extracted from the SDI data, or captured from a microphone or line source. Audio is compressed and multiplexed into a transport stream along with compressed video.

The 2267 is a UVC (USB Video Class) device, which means it does not require a device-specific driver and can be easily controlled using popular video APIs such as DirectShow and Video4Linux. Sensoray provides Software Development Kits (SDKs) for several operating systems to accelerate application development. Our fully functional demo program illustrates model 2267's capabilities and serves as an excellent starting point for custom designs.

The video processor implements efficient H.264 video compression, producing output data formatted as either MPEG transport stream (MPEG-TS) or in MP4 or AVI file formats. Audio compression is performed using AAC-LC. The stream multiplexer employs high precision hardware timestamps to ensure perfect audio-video sync on players. Snapshot capture is also supported, with MJPEG compression available for both snapshots and AVI streams.

# System requirements

Supported operating systems:

Windows 7, 8, 10;

Linux 2.6, 3.x, 4.x.

# Block diagram

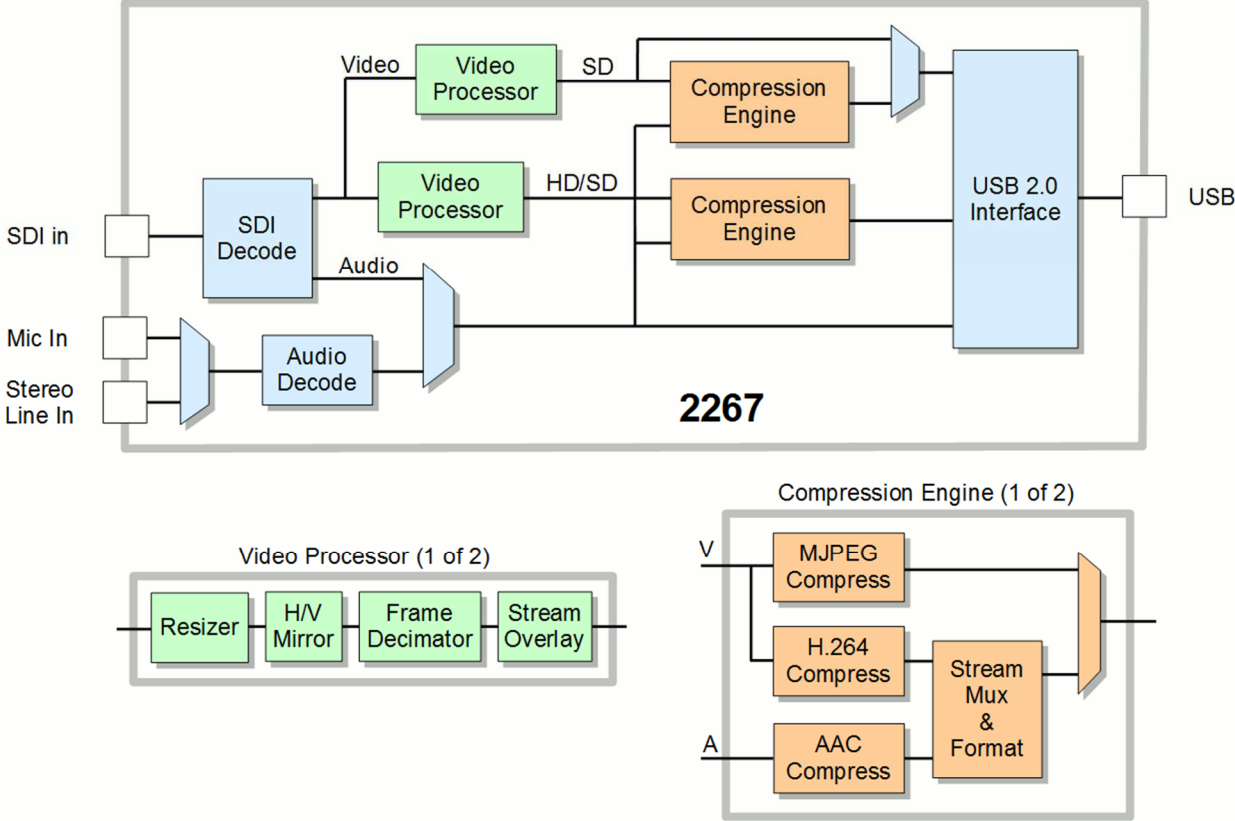

Fig.1. Model 2267 block diagram.

# Connectors

## **USB, J1**

Molex 53047-0410

Pin	Signal
1	Ground
2	DP
3	DM
4	VBUS

## **Audio inputs, JP1**

Molex 0532610771

Pin	Signal
1	Ground
2	Mic input +
3	Mic input -
4	Ground
5	Line in, right
6	Ground
7	Line in, left

Note: microphone input expects an electret condenser microphone:

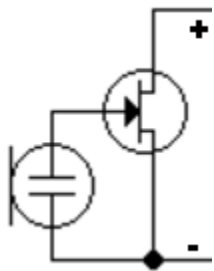

## **RS232, GPIO, JP2**

Molex 0532610671

Pin	Signal
1	Vin, external power (5V) in DVR mode
2	Ground
3	RS2323 RX
4	RS232 TX
5	Ground
6	GPIO

Note: No specific RS232 and GPIO functionality is implemented. Please contact Sensoray to discuss the requirements.



# Specifications

Video Input	
Data rates	270 Mbps, 1.483 Gbps, 1.485 Gbps
Standards	SMPTE 259M(C), SMPTE 292M
Maximum resolution/frame rate	1920x1080p30 (compressed)
Connector	BNC, 75 Ohm
Output video streams	
H.264	High Profile @ Level 3 (MP4, AVI, transport stream)
JPEG	Single snapshots, AVI
Raw (uncompressed)	UYVY
Audio inputs	
Stereo line	10 kOhm
Microphone	electret type
Electrical, mechanical and environmental	
Dimensions	26.9x59.4 mm (PCB outline, does not include the BNC connector)
Mass	23 g (without an enclosure)
Operating temperature	-20° to 70° C (active cooling may be required)
Interface	USB 2.0
Power	USB bus powered

# Software

Software (Windows and Linux)	
Driver	UVC video
SDK	Library wrappers around the DirectShow (Windows) or V4L2 (Linux) APIs

## Firmware updates

Firmware can be updated by selecting an Update option in the demo application or by calling the corresponding SDK function. Upon those actions the device reconnects as a USB mass storage device with the name Update2263. (If the AutoPlay menu appears, choose the "Open folder to view files option"). In this mode, a new firmware file may be copied to the Update2263 folder. While the file is being written to the flash memory, the red LED blinks. Do not unplug the device while the red LED is blinking. After the update is complete, the Update2263 folder is closed, and the 2267 reconnects as a UVC device. To cancel the update mode without updating firmware, right click the Update2263 removable device in Computer and click Eject. In case a firmware update was interrupted in a way that prevents the device from operating, the original firmware will be loaded automatically after the watchdog timer has expired (approximately 30 seconds). This will be indicated by the "SAFE" red LED on the daughter board turning on.

## Revision history

Version	Notes
1.0.2, July 2024	Removed reference to SD card.
1.0.1, December 2019	Connectors pinout information added.
1.0.0, August 2018	Initial release.